

AMP6

DESCRIPTION

Six-Channel HiFi Amplifier

The AlsterAero AMP6 integrates a fully digital six-channel power amplifier with an Ethernet connected sound processor. This allows for fully digital signal routing and processing all the way from a multimedia source like an AVOD server to the loudspeaker outputs of the AMP6.

Each of the output channels provides up to 125W into eight Ohms, and each channel is software configurable to act as any of mono, stereo or surround sound outputs. As an example this configurability allows to use the AMP6 as three integrated stereo amplifiers.

In addition to its Ethernet interface, the AMP6 is equipped with up to three standard synchronous stereo digital AES/EBU audio inputs. These may be used to interface aircraft audio sources like passenger address, connector panels like AlsterAero's AHCP and other PAX equipment to the amplifier.

As an orderable option, the AMP6 can be equipped with an additional emergency DC power input, required by using the AMP6 for passenger address.

- with cooling air hood



- without cooling air hood

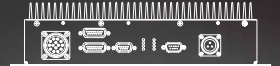

FEATURES

- 6 x 125W output power
- integrated Ethernet audio decoder and sound processor
- channels individually software configurable for mono, stereo and surround sound.
- up to six direct digital AES and S/PDIF inputs
- hood for cooling air supply for direct CCS connection (orderable option)
- 115VAC WF power input
- emergency battery supply power input for passenger address (orderable option)

OUTLINE DRAWING

dimensions are millimeter (mm)

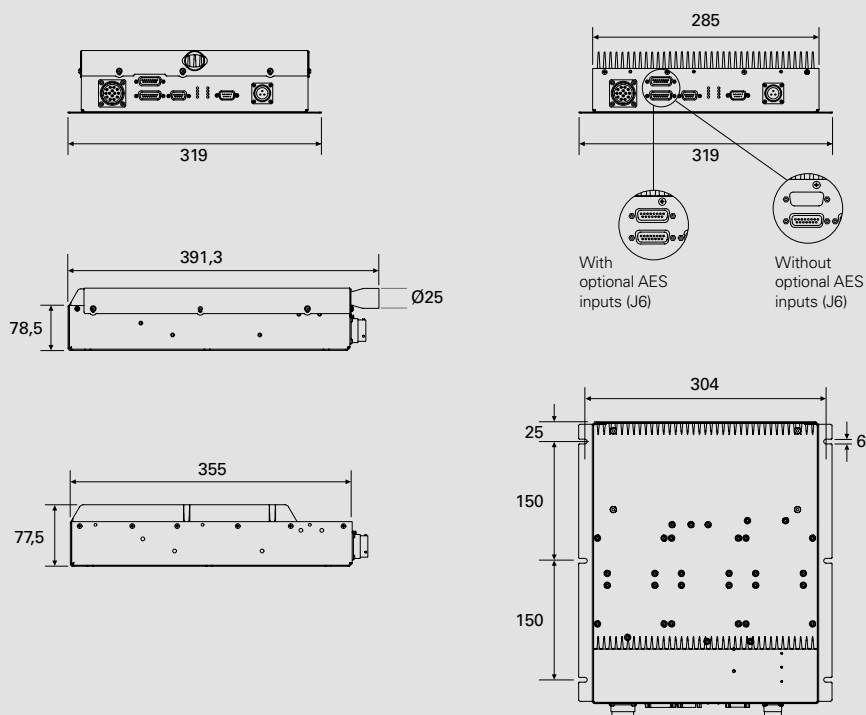

QUALIFICATION

- DO160

CONTACT

AlsterAero GmbH
 Heidenkampsweg 43
 20097 Hamburg
 Germany

phone : +49 (0) 40 2482712-0
fax : +49 (0) 40 2482712-22



email : info@alsteraero.com
web : www.alsteraero.com